

# Design and Analysis Of Multipurpose Power Weeder

Shubham Raktate, Kolge Omkar, Shubham Gunjal, Prof.Swapnil.S.Shinde

**Abstract**— Earlier farmers were using Traditional farming method which is time consuming, hardworking and costly, hence we introduce new technology. Generally, the machines are used for the farming purpose in India which is of higher level. All machines were used in farms are costlier and not affordable to farmers, hence to overcome this problem we were make this model. This working model of mini cultivator, we were done their trial on the farms and results are being successful and achieve our main aim to make this model. In this paper we can directly discuss about the working machinery which would be work in one and half hector for tilling purpose. This modern technology we were introduce, plough will be getting moves in forward and base wheel moves rotating with blades having traction effect.

**Keywords:** Multipurpose weeder, weed, cultivation, chemical weeding, seed drill and fertilizers.

## 1 INTRODUCTION

As we know that the soil tiller and cultivator is one of the many farm mechanization and soil/ power tillers frequently named as walking tractors has been used as an equipment to prepare/use for farming and for transportation We were getting reference from OLEO-MAC Company. The company would make rotary tiller (MH-195) which is having less torque and more speed, which is not suitable for Indian farming, hence to overcome this drawback we were making model based on combination of plough tiller and cultivator instead rotary tiller.

The design development and fabrication of soil tiller and cultivator is a system which can be used in small lands around 1.5-3 acres due to its light weight (30-35 kg) and low power (4.5-6 HP). Anybody would be handled this cultivator.

Farmers are facing issues such as shortage of labour, labour cost and tractor cost. Therefore, solution need to be find for this whole problem, thus combination of users, survey and expert view point will be used to make the design and fabrication of soil tiller and cultivator.

A seed drill is a sowing device that precisely positions seeds in the soil and then covers them. The modern seed -drill allows seed drilling without prior tilling. This means that soil subject to erosion or moisture loss is protected until the seed germinates and grows enough to keep the soil in place.

## 2 LITERATURE REVIEW

In this review we gone through various aspects of Machines set up in various parts of world for the purpose of Tilling. In order to carry out this work we have undergone extensive research of topic and contribution of by various authors is as follows, D.A. Mada, Sunday Mahai, [2013] [1] concluded that the importance of mechanization in agricultural. The information from the paper was need of multifunctional vehicle for pre-and post-harvesting. We have taken this as base for our research and further production of our multifunctional agricultural vehicle. F.A. Adamu, B. G. Jahun and B. Babangida [2014] [2] . In his paper authors draws our attention towards the performance factor of a power tiller. Among those demand for light weight power tiller was sought out most. Fuel efficiency and field capacity of such parameters are also dis-

ussed. we take those points in consideration while designing a sustainable multifunctional agricultural vehicle. Md. Aqib Naque, Akhtar Ali Rizvi [2013] [4]. This machine is developed to reduce the time and effort required for production up to the great extent. Also, this machine manufacturing cost is less as compared to other, by selecting above topic we are understand, familiar and know the details of agricultural technology, with the help of this machine we are trying to reduce labour cost, time of a middle class and small sector farmers. Kshirsagar Prashant, KuldipGhotane [2016] [5]. This research it will of small scale farm. By employing this in real will help in faster rate of bowing, fertilizer spreading and grass erupting. Biswas H S, [1990] [6] Indian Institute of Technology, Kharagpur, India. 283p. In this research paper, we got the method for selection of tool depends on moisture contents in soil

## 3 WORKING PRINCIPLE

In this paper, engine is placed at top of model and with the help of engine belt of pulley going to rotated and with help belt chain is rotated. The wheel shaft is rotated with the help chain and wheel base with blades are going to start its rolling motion, due to tractive effort, plough is moving forward in linear direction. For support and changing the direction of plough handle is placed.

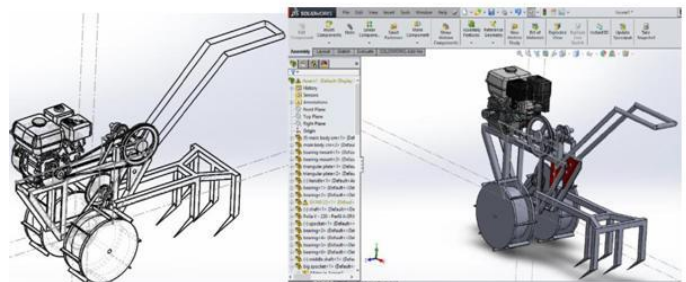

### 3.1 MAIN BODY

On the main body we mounted all the necessary parts which is used, such as engine, wheels, plough, handle, drives etc.

Beam - L Shape

Material - MS

Number of members - 14

Ground clearance - 180mm

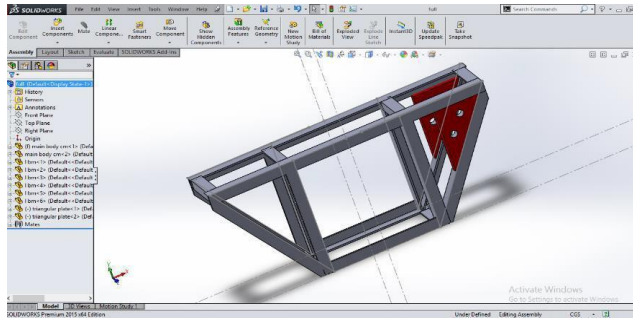

### 3.2 WHEEL

It is basically use for moving purpose which are move the overall body ahead. Blades are mounted on wheel for achieve traction effect.

Diameter - 360mm

Width - 160mm

Material - MS

Number of blades - 8 on each wheel

Number of wheel - 2

Track width - 540mm

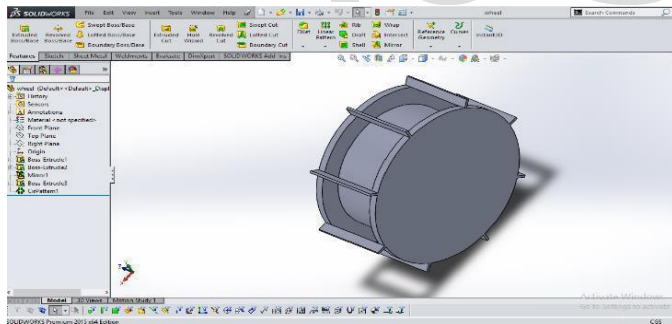

### 3.3 PLOUGH

The main aim of plough for initial cavitations of soil in preparation for bowing seed.

Number of blades - 5

Material - MS

Beam type - L shape

Angle -215°



Tilling Depth - Min 4 inch

### 3.4 Speed reduction unit

We are using three different stages to reduce speed to get maximum torques we required for this machine, there are two units are as follows:

**3.5 Belt Drive** - It may be used as source of motion to transmit power efficiently track relative movement. Belts are looped over pulley and may have twist between the pulleys, and the shafts need not be parallel.

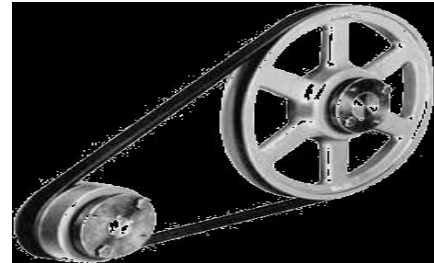

Type - A, V-Belt

Big pulley - 300mm

Small pulley - 50mm

**3.6 Chain Drive** - It is a way of transmitting mechanical power from one place to another. It used to convey power to the wheel of a vehicle particle



Simplex, ISO12A-1

Small sprocket - 14 teethes

Big sprocket - 39 teethes

Type -

### 3.7 Seed Drill and Fertilizer Box

4

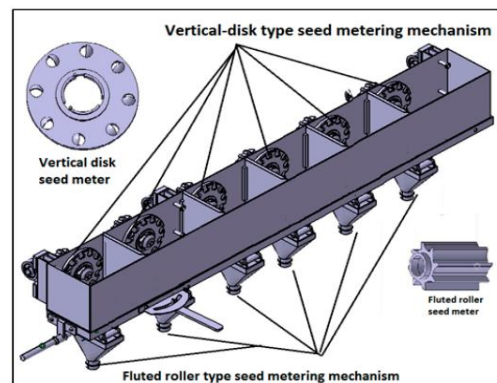

Figure 2. Seed box with vertical disk and fluted roller type seed metering mechanisms.

### CALCULATION

Engine speed (N1) = 3000 rpm,

Engine power (P) = 3.355 kw  
(4.5 HP)

Diameter of small pulley (D1) = 50mm

Diameter of big pulley (D2) = 300mm

Number of teeth on small sprocket (T1) = 14

Number of teeth on big sprocket (T2) = 39

First stage,

$$\frac{N_1}{N_2} = \frac{T_2}{T_1}$$

N2 = 500 rpm

t1 = 64.075 \* 10<sup>3</sup> N-mm

Second Stage,

$$\frac{N_2}{N_3} = \frac{T_3}{T_2}$$

N3 = 180 rpm

t2 = 177.988 \* 10<sup>3</sup> N-mm

Third Stage,

$$\frac{N_3}{N_4} = \frac{T_4}{T_3}$$

N4 = 65 rpm

t3 = 492.89 \* 10<sup>3</sup> N-mm

Final Speed = 65 rpm

Final torque = 492.89 \* 10<sup>3</sup> N-mm

#### Calculations for Power Required To Power Weeder

##### Machine

Power required to weeding blade

Power = Soil resistance × Area × Velocity

Soil Resistance (S.R) = 1.05 Kgf/cm<sup>2</sup>

$$= 1.05 * \frac{1000}{10000} \text{N/m}^2$$

$$= 103005 \text{ N/m}^2$$

Area (A) = Depth of Cut (mm) × Width of Cut (mm)

$$= 5 \times 0.25$$

$$= 27.5 \times 10^{-3} \text{ m}^2$$

$$\text{Linear Velocity (V)} = \frac{\pi D N}{60} \times \mu$$

Where,

μ = Coefficient of Friction = 0.1

N = 500 R.P.M

$$\text{Linear Velocity} = \frac{\pi D N}{60} \times 0.1$$

$$= 0.89117 \text{ m/s}$$

Power = Soil resistance × Area × Velocity

$$\text{Power} = 103005 \times 27.5 \times 10^{-3} \times 0.89117$$

$$= 2524.38 \text{ W}$$

$$= \frac{2524.38}{746} \text{ hp}$$

$$= 3.3838 \text{ hp}$$

Total Power

$$P = \frac{\text{Power}}{\eta} = \frac{2524.38}{600} = 4.22 \text{ hp}$$

Where,

η = Transmission efficiency.

## 5 RESULTS AND OUTCOMES

Power weeder offered by us are devices used for removing the weeds, stirring and pulverizing the soil and for loosening the soil after the crop has begun to grow. We manufacture these power weeder using high quality raw materials with the help of latest machines.

These machines are widely used for weeding cotton, tomato, tapioca, paddy, sugarcane, pulses and various other plant fields. This rotary power weeder consists of high speed motors, tiling width of these power weeder ranges from 40-60 cm and the tiling depth ranges from 10-15cm.

The machine helps to place the seeds properly by providing necessary space between them, which also increases the productivity

The weed removal also becomes easy due to the space provided between the seeds during the sowing process

## 6 Acknowledgments

It gives us great pleasure to present a project report on "DESIGN AND ANALYSIS OF MULTIPURPOSE POWER WEEDER". In preparing this project report number of hands helped us directly and indirectly. Therefore it becomes my duty to express my gratitude towards them.

We are very much obliged to Project guide Prof. Swapnil S .Shinde of Mechanical Engineering Department, for helping and giving proper guidance. There timely suggestions made it possible to complete this report. All efforts might have gone in vain without their valuable guidance.

I will fail in my duty if I won't acknowledge a great sense of gratitude to our Prof. V. M. Ugare (Project coordinator), Dr.

S.M. Gaikwad (HOD), Dr. M.S. Gaikwad (Principal) and the entire staff members in Mechanical Engineering Department for their co-operation.

JAVS) e-ISSN: 2319-2380, p-ISSN: 2319-2372. Volume 9, Issue 1 Ver. II (Jan. 2016)

## 7 Conclusion

Based on the overall performance of the machine we can definitely say that the project will satisfy the need of small scale farmer, because they are not able to purchase costly agricultural equipment.

The machine required less man power and less time compared to traditional methods, so if we manufacture it on a large scale its cost gets significantly reduce and we hope this will satisfy the partial thrust of Indian agriculture.

So in this way we can solve the labour problem that is the need of today's farming in India.

In the Indian agricultural scenario 62 % people hold land below 1 ha covering 18 % of the total area cultivated. 44% of the area of land is divided in pieces of 1ha to 4ha.

Only 1% people hold land above 10ha with area covered is approximately 13%. Hence the power tillers are not suitable for Indian scenario.

Power tillers are used by many farmers in medium land holding. At lower end with very low land holding farmers use manual weeding methods over any mechanization.

## 8 References

[1] D.A. Mada, Sunday Mahai, "The Role of Agricultural Mechanization in the Economic Development for Small Scale Farms in Adamawa State", The International Journal of Engineering and Science (IJES) || Volume || 2 || Issue || 11

[2] F.A. Adamu, B. G. Jahun and B. Babangida "Performance Evaluation of Power Tiller in Bauchi State Nigeria Agriculture and Healthcare 2224-3208 (Paper) ISSN 2225 Vol.4, No.9, 2014

[3]nG. C. Kiss and D. G. Bellow AN ANALYSIS OF FORCES ON CULTIVATOR SWEEPS AND SPIKES Department of Mechanical Engineering, University of Alberta, Edmonton, Aha. T6G 2G5 Received 11 August 1981

[4] Md. AqibNaque, Akhtar Ali Rizvi, Amogh v. Tijare, Prof. A. B. Tupkar Design, Development and Fabrication of Soil Tiller and Weeder Mechanical Engg. Dept. P. C. E. Nagpur, Maharashtra, India (IJET) Vol. 2 Issue 2 April 2013

[5] Kshirsagar Prashant R, Kuldip Ghotane, Pritesh Kadam, Omka R Arekar, Ketan Insulkar Assistant Professor, Final Year Students, Modeling and Analysis of Multifunctional Agricultural Vehicle, Department of Mechanical Engineering, RMCET, Ambav (Devruk), Ratnagiri Maharashtra, India. International Journal of Research in Advent Technology, Vol.4, No.1, January 2016 E-ISSN: 2321-9637

[6] Mrinal Verma1, Dr. J.P. Gupta2 "Development and Testing Of Power Tiller Operated Multicrop Seed cum Fertilizer Drill" IOSR Journal of Agriculture and Veterinary Science (IOSR-